

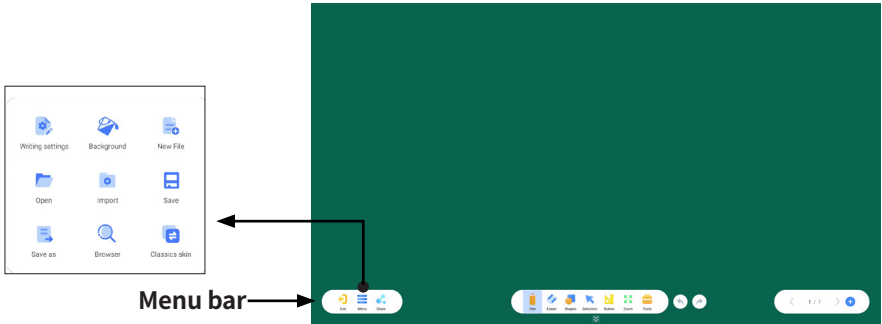















# **UBoardMate 3**

## **INSTRUCTION MANUAL**

# BASIC OPERATION

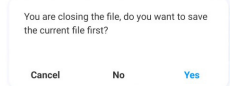













 Menu	 Writing settings	Set the behavior of pen and finger
	 Background	Set the background of the canvas
	 New File	Create a new file
	 Open	Open local files in formats such as (ubmx, pdf, ubc, iw b)
	 Import	Insert Image in (jpeg, svg) format
	 Save	Save the current courseware in ubmx format
	 Save as	Export current courseware in fomrats such as (jpeg, pdf, ubc, iw b, svg)
	 Browser	Open browser
	 Classics skin	Switch UI style to Classics or Modern skin .
 Exit	<p>Click the button to exit UBM. If the content has not been saved, UBM will prompt as below picture whether to save before exiting.</p>  <p>Cancel    No    Yes</p> <p>Cancel to back to UBM. No to exit without saving. Yes to save the content before exiting.</p>	
 Share	Sharing content through cloud storage, or QR code while internet is available.	

# BASIC OPERATION

---



- Click the put away toolbar.

 Pen	Select Pen type and set properties of writing
 Eraser	Select Eraser type
 Shapes	Select commonly used shapes
 Selection	Switch to selection mode
 Rulers	Choose tools such as Ruler, Triangle ruler etc.
 Zoom	Switch to roaming mode
 Tools	Turn on the tool box
 Undo	Cancel operation
 Redo	Restore operation
 Previous Page	Previous Page
 Next page	Next page
 add page	Add a new page

# SETTINGS MENU

## Writing settings

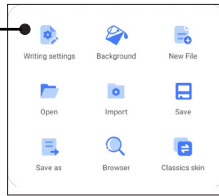

Click to enter writing settings.

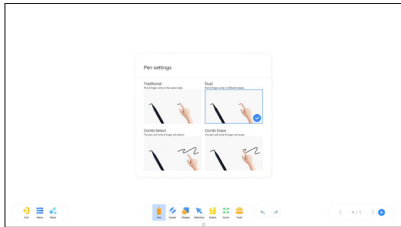

## Background

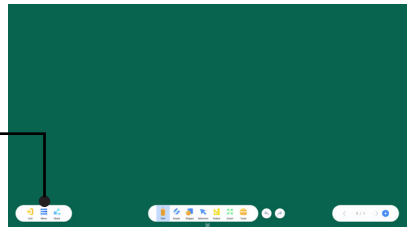
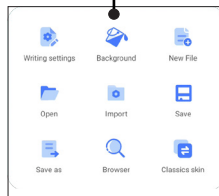

Set the background.

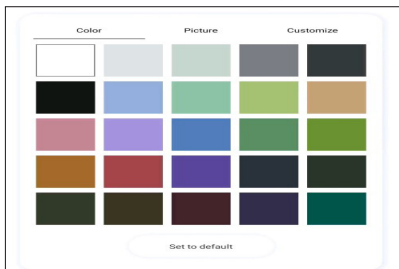

# SETTINGS MENU



## New File

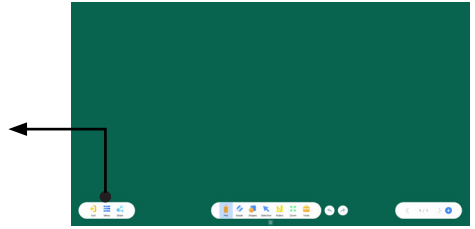
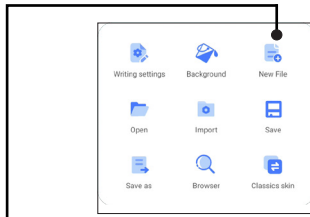

Click new file.

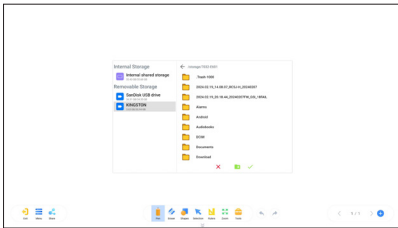

## Open

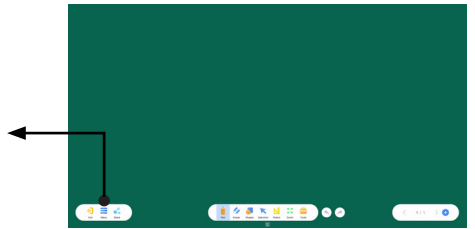
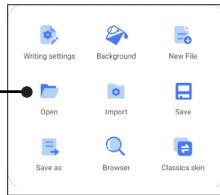

Click open file.

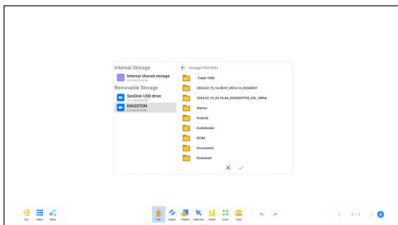

# SETTINGS MENU

## Import

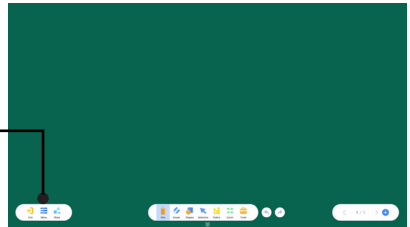
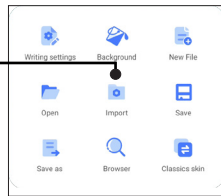

Import pictures.



## Save

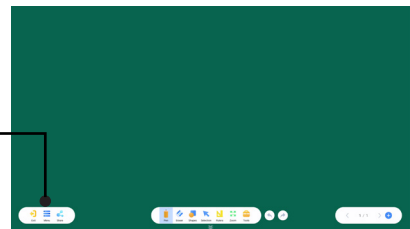
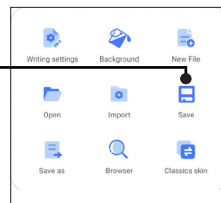

Save the current courseware.

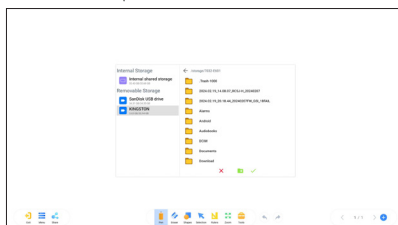

# SETTINGS MENU

## Save as

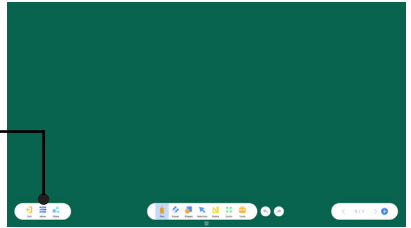
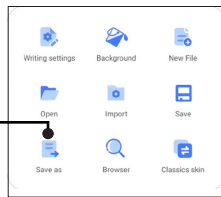

Go to File and then click on Save As.

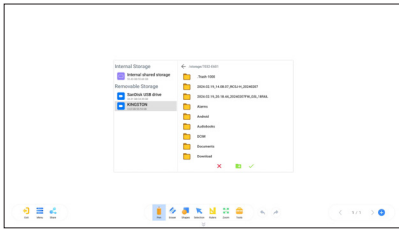

## Browser

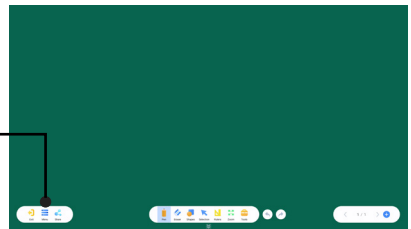
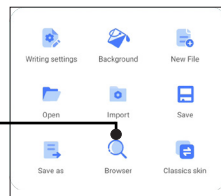

Click open browse.



# SETTINGS MENU

---

## Classics skin

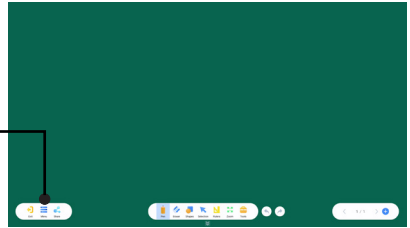
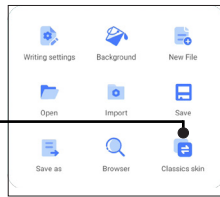

Click to switch the user interface style to classic or modern skin.

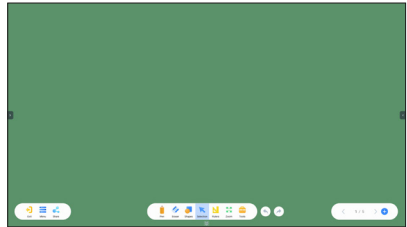
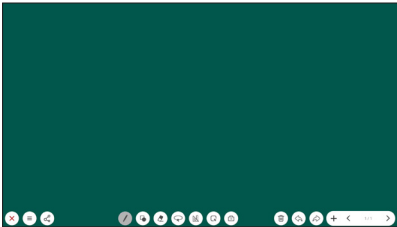



# TOOL USAGE

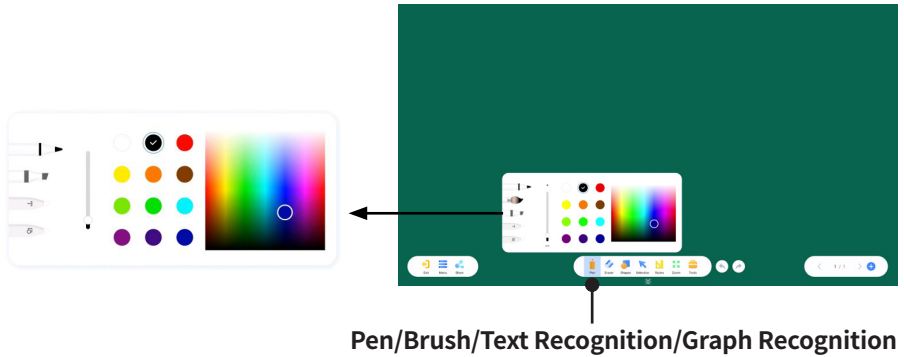

- ① Click the pen button on the left to switch pen types.
- ② Drag the slider to modify the thickness of the note.
- ③ Click on the color block to select a preset pen color.
- ④ Drag the color palette to customize pen colors.

Text Recognition: Recognize handwriting as standard font and display it.  
Note: Before using this feature, the network should be connected to download the font library.

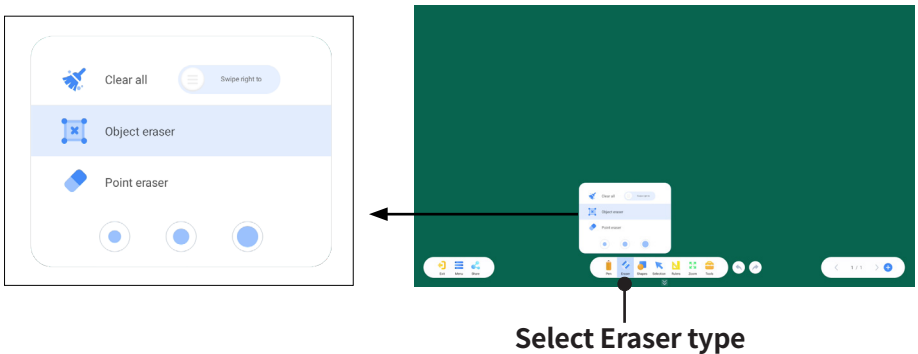

- ① Swipe to clear the canvas.
- ② Object wiping: Wiping the selected object.
- ③ Dot wipe: Wiping the writing
- ④ Three types of dot eraser size selection.

# TOOL USAGE

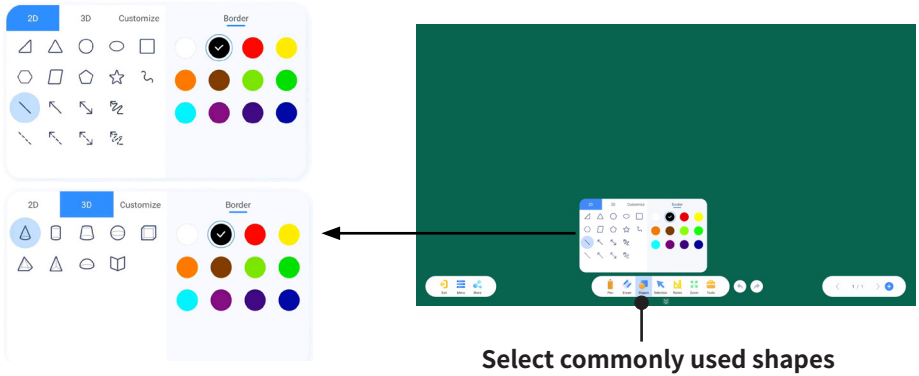

- ① Click 2D to switch to a flat graphic.
- ② Click on 3D to switch to 3D graphics.
- ③ Click Customize to switch to a custom graphic and add images to it.
- ④ Click the graphic button to switch graphics.
- ⑤ Click to select the Border and then click on the color block to switch the border color.
- ⑥ Click to select Fill and then click on the color block to switch the fill color.

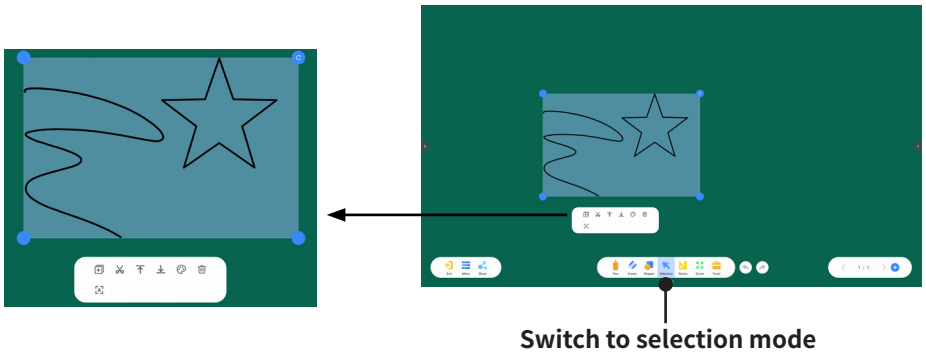

Copy, cut, MoveToTop, MoveToBottom, Color, delete and recognize etc. on selected object.

# TOOL USAGE

---

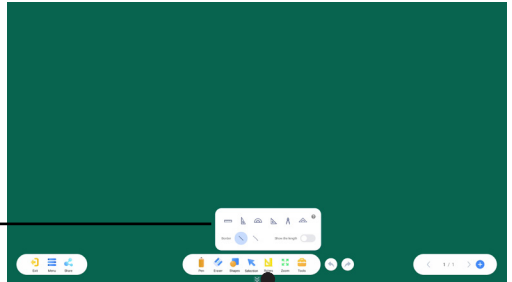
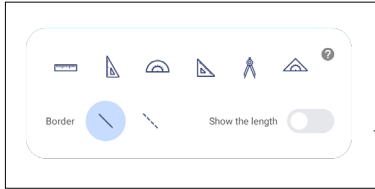

Choose tools such as Ruler, Triangle ruler etc

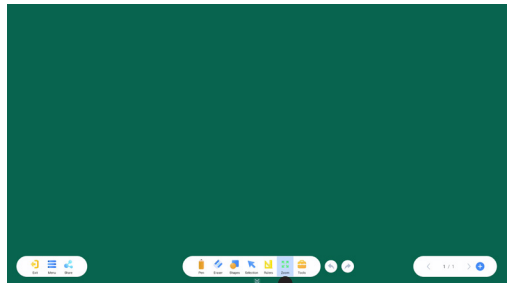

Switch to roaming mode

# TOOL USAGE

---

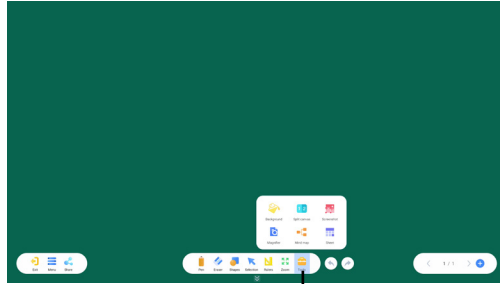

Turn on the tool box

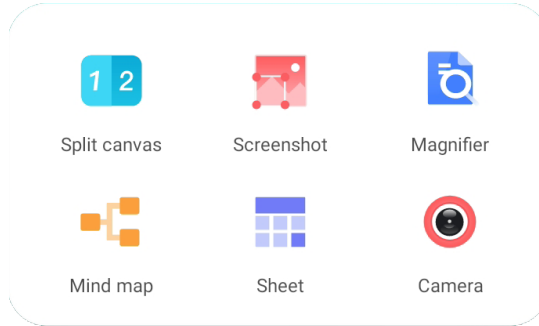

- ① Click on Split Canvas to enter split screen.
- ② Click on Screenshot to enter the screenshot page.
- ③ Click on Magnifier to open the magnifying glass.
- ④ Click Mind map to go to the mind map page.
- ⑤ Click on Sheet to open the Insert Table pop-up window.
- ⑥ Click on Camera to enter the high-definition camera.

The background color and background image can be set separately, and can be set as the default background.

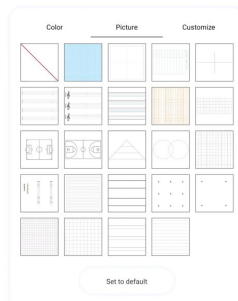
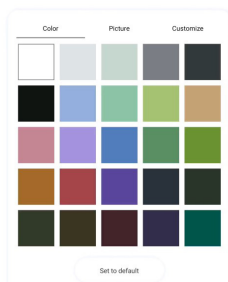

# TOOL USAGE

---

Set border and fill color of the sheet.

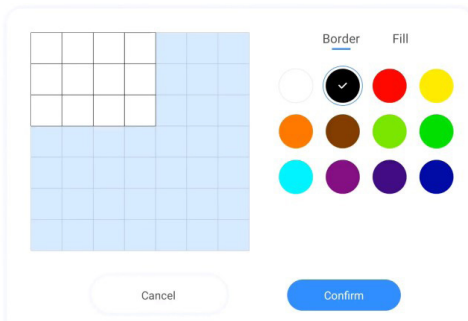

Insert a row or column.

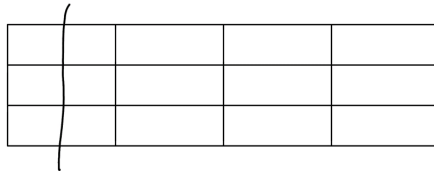

Delete a row or column.

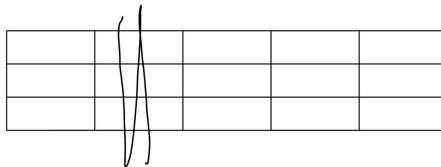

# TOOL USAGE

---

## Split screen mode function

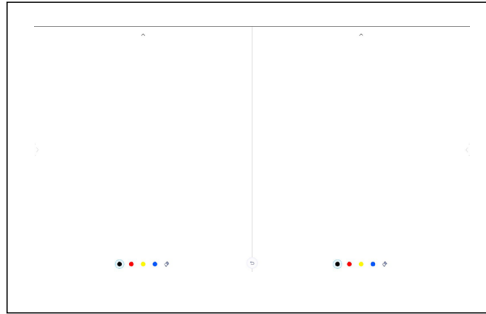

- ① Click the color button to change the pen color.
- ② Click the button to switch to eraser.
- ③ Click the upper triangle to switch the UI position.
- ④ Click the middle left button to exit the split screen.
- ⑤ Click the right button in the middle to save the split screen content as a picture.

## Preview pop-up function

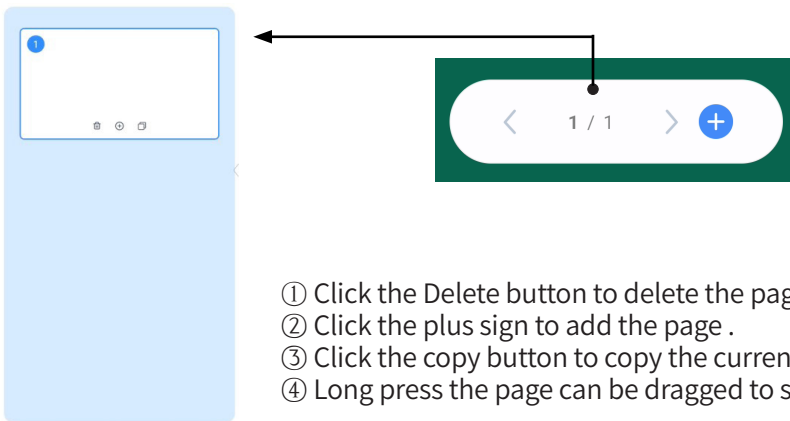

- ① Click the Delete button to delete the page.
- ② Click the plus sign to add the page .
- ③ Click the copy button to copy the current page.
- ④ Long press the page can be dragged to sort.